

# LCC Series

## V-SHAPED AIR-COOLED CONDENSERS

- ▶ LOW-CHARGE MICROCHANNEL HEAT EXCHANGERS
- ▶ HIGH HEAT REJECTION DENSITY
- ▶ EFFICIENT EC-MOTOR FANS
- ▶ MULTI-REFRIGERANT



TECHNICAL MANUAL  
ENGLISH

# 100-800kW



MODEL IDENTIFICATION

LCC			MC	V	2	.	1	-	E	80	-	2	-	3	/	N	-	1	-	R454c
Heat exchanger type	MC	Microchannel aluminium coil																		
Unit shape	V	V-shaped																		
Number of coils																				
Number of passes																				
Fan motor type	E	EC-motor																		
	A	AC-motor																		
Fan diameter		cm																		
Number of fans																				
Power supply	1	230V/1Ph/50Hz																		
	3	400V/3Ph/50Hz																		
Noise level	N	Normal																		
	L	Low																		
	U	Ultra-low																		
Number of circuits																				
Refrigerant type		ASHRAE number																		

The model code can be found on the name plate under the front cover of the unit (unit connection side):



**Kaltra Innovativtechnik GmbH**  
 Max-Reger-Str. 44  
 90571 Schwaig  
 Germany  
 Tel.: +49 (0) 911 715 320 21  
 Email: info@kaltra.de

UNIT SERIES  
**LCC**

MODEL  
**MCV 2.1-E80-2-3/N-1-R454c**

Supply voltage	[V/Ph/Hz]	400/3/50
Absorbed current [FLA]	[A]	4.86
Refrigerant	HFC/HFO	- [kg]
Volume	[L]	8.9

Serial number      M18-00445  
 Year of manufacturing      2018

Made in EU



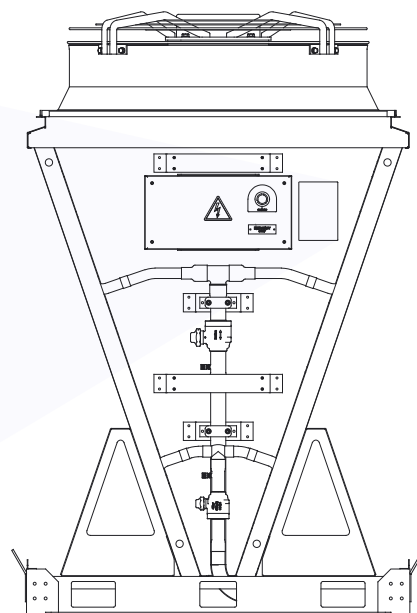

## UNIT COMPONENTS AND CONSTRUCTION

### Painted Galvanized Steel Enclosure

The unit shall be coated with epoxy baked powder paint to provide a durable finish. The paint color shall be Signal White (RAL 9003) or similar.

### Electronically Commutated (EC) Fan Motor

The fans shall incorporate external EC rotor motor technology to provide highly accurate discreet speed control. The fans offer maximum airflow performance while keeping sound levels to a minimum.

Each fan shall incorporate electronically commutated DC motor control using semiconductor modules responding to a signal from the indoor unit or an independent control module for standalone units.

### Microchannel Heat Exchanger

Large surface area heat exchanger positioned to optimise airflow and heat transfer, shall be manufactured from microchannel coil with multi-port flat tubes and louvered fins, optionally epoxy coated. The factory test pressure shall not be less than 45 bar.

### Electrical Components and Wiring - Optional

All electrical components shall be rated for all year round outdoor use. All wiring (optional) shall be color coded and numbered for identification. All units shall be wired in accordance with current European standards.

### Main Electric Isolator - Optional

A weatherproof mains isolator shall be fitted to ensure complete unit isolation of the electrical panel during adjustment and maintenance.

### Inert Holding Charge

The unit shall be shipped with a holding charge of inert gas.

### Head Pressure Control - Optional

Head pressure control shall be fitted to the condenser for low-ambient operation. Head pressure control utilizes a pressure differential valve that responds to changes in the pressure difference across the valve. When the differential reaches setpoint, the control valve starts to open and bypasses hot gas to the liquid line. As the differential increases, the valve opens further until its full stroke is reached.

### Coil Guard - Optional

Protective mesh guards can be fitted to each of the outer coils to protect against damage and shall be removable.

### Air Filtration - Optional

The air filtration media shall be heavy duty commercial grade polycarbonate that can be removed for maintenance purposes.

### Epoxy Coating - Optional

Epoxy electrocoated microchannel heat exchanger offers the ultimate corrosion and chemical resistance, provide excellent salt spray and humidity resistance and exhibit outstanding performance over aluminium.

### Shut-off Valves - Optional

The unit can be fitted with shut-off valves on liquid and discharge lines.

### Discharge Air Plenum - Optional

Factory fitted, constructed from galvanized sheet steel and coated with epoxy baked powder paint, this plenum shall direct discharge air vertically which reduces air recirculation and provides a degree of acoustic reduction in the horizontal plane.

### Refrigerant Gas Leakage Detection - Optional

Gas-specific, factory-calibrated refrigerant gas leak detection system designed to meet the needs of the F-Gas regulations. The detector can be integrated into third party monitoring and/or BMS system.

### Fan Diffusers - Optional

Factory fitted fan diffusers to boost fan efficiency and reduce the operating noise of the unit.

### Variable Speed Control - Optional

The fan speed is controlled via alteration of the supply voltage which corresponds to a particular condensing pressure. The pressure set point corresponding to the maximum output voltage can be adjusted by means of a potentiometer internal to the case of the controller.

### Mini-receiver

Mini-receiver is based on a oversized coil manifold to accumulate and hold liquid refrigerant. Excess refrigerant charge is allowed to backup into the lower manifold, and help optimize the system charge and operation. This feature improves part-load operation and helps reduce critical charging of the system.

Unit model	NORMAL NOISE LEVEL	LOW NOISE LEVEL	ULTRA-LOW NOISE LEVEL	HIGH-PERFORMANCE FANS
Painted galvanized steel enclosure	■	■	■	■
Electronically commutated (EC) fan motors	■	■	■	■
Microchannel heat exchanger	■	■	■	■
Schraeder valves on liquid/discharge lines	■	■	■	■
Electrical components and wiring	□	□	□	□
Main electric isolator	□	□	□	□
Head pressure control	□	□	□	□
Coil guard	□	□	□	□
Air filtration	□	□	□	□
Coil epoxy coating	□	□	□	□
Shut-off valves (loose)	□	□	□	□
Discharge air plenum	□	□	□	□
Fan diffusers	-	-	-	■
Refrigerant gas leakage detection	□	□	□	□
Variable speed control w/ Modbus	□	□	□	□
Mini-receiver	■	■	■	■

- Standard features
- Optional features
- Feature not available

## TECHNICAL DATA - NORMAL NOISE LEVEL

LCC Series		MCV 2.1-E80-2-3/N-1	MCV 4.1-E80-4-3/N-1	MCV 6.1-E80-6-3/N-1	MCV 8.1-E80-8-3/N-1
Performance R404a					
Heat rejection	kW	172.4	344.8	517.2	689.6
Refrigerant pressure drop	kPa	19.9	19.9	19.9	19.9
Dimensions					
Length	mm	1125	2165	3205	4245
Width	mm	2350	2350	2350	2350
Height	mm	1640	1640	1640	1640
Heat exchanger(s)					
Quantity		2	4	6	8
Face area	m <sup>2</sup>	4.52	9.04	13.57	18.09
Coil volume	L	12.4	24.8	37.2	49.6
Inlet air velocity	m/s	2.5	2.5	2.5	2.5
No. of circuits		2	2	2	2
Fan(s) - EC-type					
Quantity		2	4	6	2
Diameter	mm	800	800	800	800
Airflow - total	m <sup>3</sup> /s	40000	80000	120000	160000
Rotation speed	RPM	930	930	930	930
Motor size	kW	1.95	1.95	1.95	1.95
Sound					
Sound power	dB(A)	79	79	79	79
Sound pressure level @ 10m	dB(A)	51	51	51	51
Electrical					
Mains supply		400V/3Ph/50Hz	400V/3Ph/50Hz	400V/3Ph/50Hz	400V/3Ph/50Hz
Power input - total	kW	3.12	6.24	9.35	12.47
Current - total	A	4.9	9.7	14.6	19.4

Condensing temperature: 50°C; Subcooling: 0K; Ambient temperature: 35°C; Air humidity: 50%

## TECHNICAL DATA - LOW NOISE LEVEL

LCC Series		MCV 2.1-E80-2-3/L-1	MCV 4.1-E80-4-3/L-1	MCV 6.1-E80-6-3/L-1	MCV 8.1-E80-8-3/L-1
Performance R404a					
Heat rejection	kW	142.0	284.0	426.0	568.0
Refrigerant pressure drop	kPa	15.4	15.4	15.4	15.4
Dimensions					
Length	mm	1125	2165	3205	4245
Width	mm	2350	2350	2350	2350
Height	mm	1640	1640	1640	1640
Heat exchanger(s)					
Quantity		2	4	6	8
Face area	m <sup>2</sup>	4.52	9.04	13.57	18.09
Coil volume	L	12.4	24.8	37.2	49.6
Inlet air velocity	m/s	2.0	2.0	2.0	2.0
No. of circuits		2	2	2	2
Fan(s) - EC-type					
Quantity		2	4	6	2
Diameter	mm	800	800	800	800
Airflow - total	m <sup>3</sup> /s	32000	64000	96000	128000
Rotation speed	RPM	760	760	760	760
Motor size	kW	1.95	1.95	1.95	1.95
Sound					
Sound power	dB(A)	73	73	73	73
Sound pressure level @ 10m	dB(A)	45	45	45	45
Electrical					
Mains supply		400V/3Ph/50Hz	400V/3Ph/50Hz	400V/3Ph/50Hz	400V/3Ph/50Hz
Power input - total	kW	1.69	3.38	5.07	6.76
Current - total	A	2.8	5.6	8.5	11.3

Condensing temperature: 50°C; Subcooling: 0K; Ambient temperature: 35°C; Air humidity: 50%

## TECHNICAL DATA - ULTRA-LOW NOISE LEVEL

LCC Series		MCV 2.1-E80-2-3/U-1	MCV 4.1-E80-4-3/U-1	MCV 6.1-E80-6-3/U-1	MCV 8.1-E80-8-3/U-1
Performance R404a					
Heat rejection	kW	109.8	219.6	329.4	439.2
Refrigerant pressure drop	kPa	11.1	11.1	11.1	11.1
Dimensions					
Length	mm	1125	2165	3205	4245
Width	mm	2350	2350	2350	2350
Height	mm	1640	1640	1640	1640
Heat exchanger(s)					
Quantity		2	4	6	8
Face area	m <sup>2</sup>	4.52	9.04	13.57	18.09
Coil volume	L	12.4	24.8	37.2	49.6
Inlet air velocity	m/s	1.5	1.5	1.5	1.5
No. of circuits		2	2	2	2
Fan(s) - EC-type					
Quantity		2	4	6	2
Diameter	mm	800	800	800	800
Airflow - total	m <sup>3</sup> /s	24000	48000	72000	96000
Rotation speed	RPM	580	580	580	580
Motor size	kW	0.83	0.83	0.83	0.83
Sound					
Sound power	dB(A)	67	67	67	67
Sound pressure level @ 10m	dB(A)	39	39	39	39
Electrical					
Mains supply		400V/3Ph/50Hz	400V/3Ph/50Hz	400V/3Ph/50Hz	400V/3Ph/50Hz
Power input - total	kW	0.82	1.64	2.46	3.28
Current - total	A	1.6	3.1	4.7	6.2

Condensing temperature: 50°C; Subcooling: 0K; Ambient temperature: 35°C; Air humidity: 50%

## TECHNICAL DATA - NORMAL NOISE LEVEL / HIGH-PERFORMANCE FANS

LCC Series		MCV 2.1-E80-2-3/N-1	MCV 4.1-E80-4-3/N-1	MCV 6.1-E80-6-3/N-1	MCV 8.1-E80-8-3/N-1
Performance R404a					
Heat rejection	kW	203.4	406.8	610.2	813.6
Refrigerant pressure drop	kPa	33.1	33.1	33.1	33.1
Dimensions					
Length	mm	1125	2165	3205	4245
Width	mm	2350	2350	2350	2350
Height	mm	1640	1640	1640	1640
Heat exchanger(s)					
Quantity		2	4	6	8
Face area	m <sup>2</sup>	4.52	9.04	13.57	18.09
Coil volume	L	12.4	24.8	37.2	49.6
Inlet air velocity	m/s	3.0	3.0	3.0	3.0
No. of circuits		2	2	2	2
Fan(s) - EC-type w/ diffusers					
Quantity		2	4	6	2
Diameter	mm	800	800	800	800
Airflow - total	m <sup>3</sup> /s	48000	96000	144000	192000
Rotation speed	RPM	1050	1050	1050	1050
Motor size	kW	2.80	2.80	2.80	2.80
Sound					
Sound power	dB(A)	80	80	80	80
Sound pressure level @ 10m	dB(A)	52	52	52	52
Electrical					
Mains supply		400V/3Ph/50Hz	400V/3Ph/50Hz	400V/3Ph/50Hz	400V/3Ph/50Hz
Power input - total	kW	4.17	8.33	12.50	16.66
Current - total	A	6.4	12.8	19.3	25.7

Condensing temperature: 50°C; Subcooling: 0K; Ambient temperature: 35°C; Air humidity: 50%

DRAWINGS - UNIT MODELS MCV 2

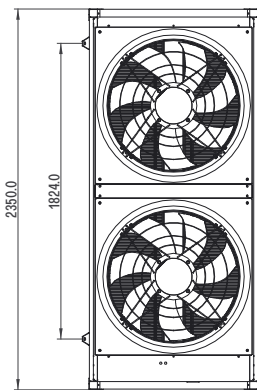
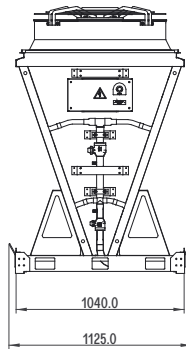
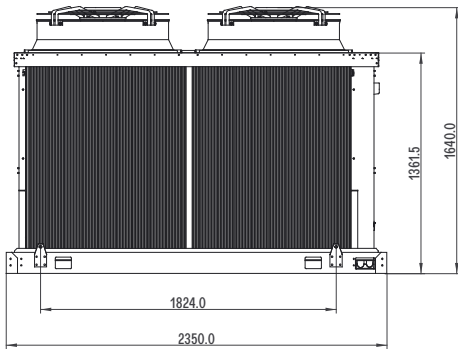

DRAWINGS - UNIT MODELS MCV 4

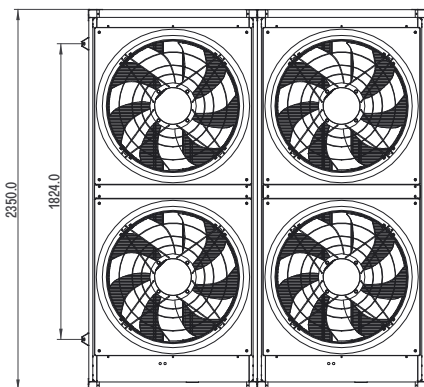
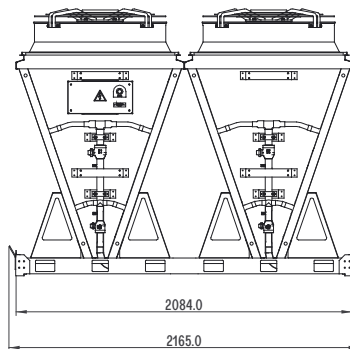
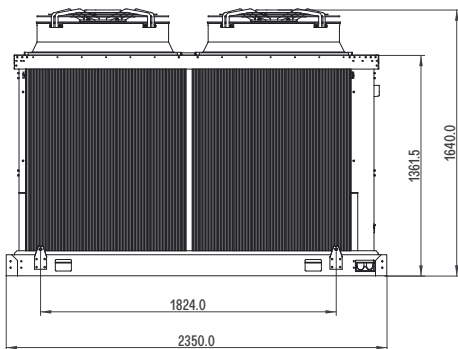

DRAWINGS - UNIT MODELS MCV 6

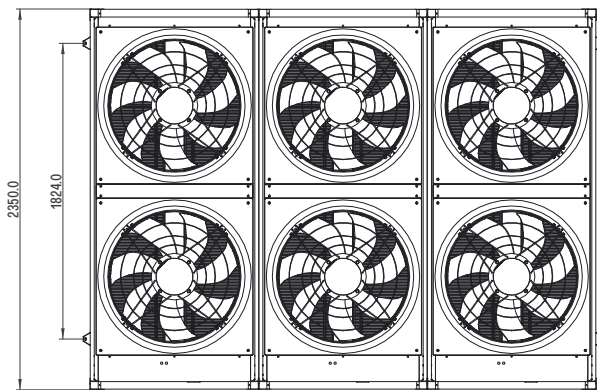
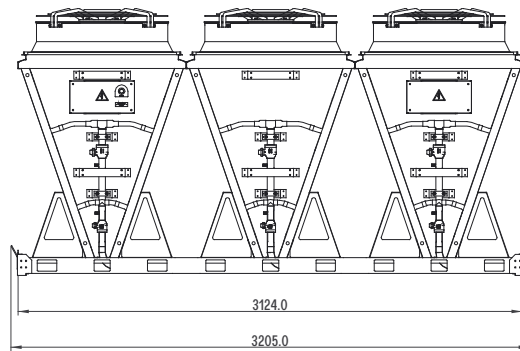
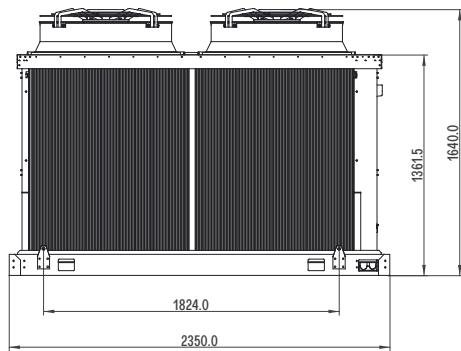

DRAWINGS - UNIT MODELS MCV 8

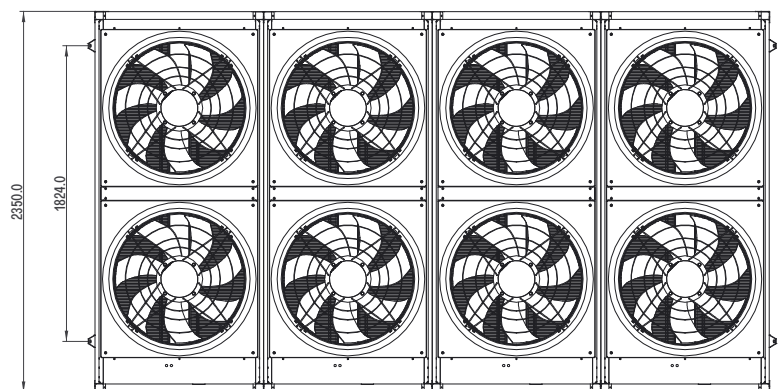
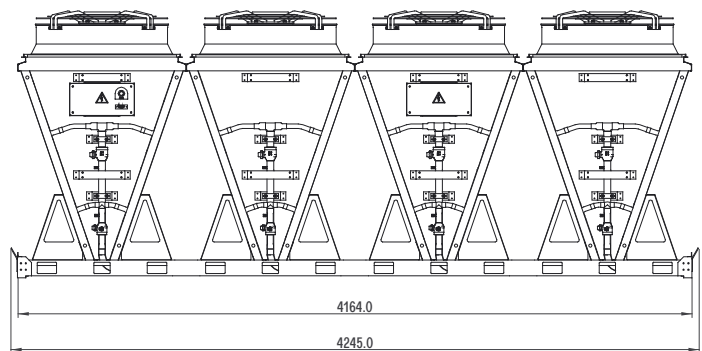
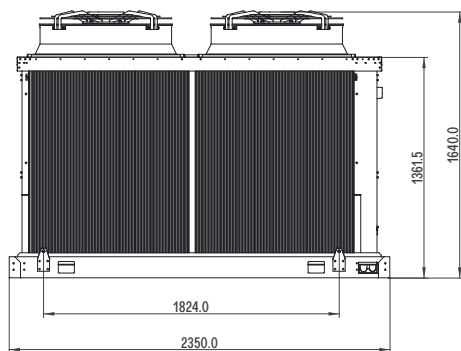



NOTES

Lined area for notes, consisting of multiple horizontal lines.



Kaltra Innovativtechnik GmbH

Head office:

Max-Reger-Str. 44  
90571 Schwaig  
Germany



+49(0)911 715 32021



info@kaltra.de



www.kaltra.com

