

Mistral Series

FLATBED DRY COOLERS

- ▶ INCREASED HEAT TRANSFER SURFACE
- ▶ HIGH-PERFORMANCE FANS
- ▶ MORE THAN 600 MODELS AVAILABLE



TECHNICAL MANUAL
ENGLISH

10-1000kW



CUSTOMER SERVICES

Commissioning, Maintenance, and Warranty

As standard, Kaltra guarantees all non-consumable parts only for a period of 36 months, variations tailored to suit product and application are also available; please contact Kaltra for full terms and details. To further protect your investment in Kaltra products, Kaltra can provide full commissioning services, comprehensive maintenance packages and service cover 24 hours a day, 365 days a year. (EU sites)

For a free quotation contact Kaltra or your local sales engineer. All Kaltra products are designed in accordance with EU Directives regarding prevention of build up of water, associated with the risk of contaminants such as legionella. For effective prevention of such risk it is necessary that the equipment is maintained in accordance with Kaltra recommendations.



CAUTION

Warranty cover is not a substitute for maintenance. Warranty cover is conditional to maintenance being carried out in accordance with the recommendations provided during the warranty period. Failure to have the maintenance procedures carried out will invalidate the warranty and any liabilities by Kaltra.

In addition to commissioning, a 24 hour, 7 days a week on-call service is available throughout the year to EU sites. This service will enable customers to contact a duty engineer outside normal working hours and receive assistance over the telephone or per email. The duty engineer can, if necessary, attend site, usually within 24 hours or less. Full details will be forwarded on acceptance of the maintenance agreement.

Spares

The list of recommended spares for 1, 3 and 5 years could be supplied with every unit and is also available from our Spares department on request.

Training

As well as our comprehensive range of products, Kaltra offers training courses. For further information please contact Kaltra.

Service Contacts

For further assistance, please e-mail: support@kaltra.de or telephone:

Sales enquiries:	+49 (0) 911 715 320 21	sales@kaltra.de
24/7 support hotline:	+49 (0) 151 418 586 90	support@kaltra.de
Information:	+49 (0) 911 715 320 21	info@kaltra.de
Delivery:	+49 (0) 911 715 320 21	delivery@kaltra.de
Spares:	+49 (0) 911 715 320 21	spares@kaltra.de

Kaltra endeavours to ensure that the information in this document is correct and fairly stated, but none of the statements are to be relied upon as a statement or representation of fact. Kaltra does not accept liability for any error or omission, or for any reliance placed on the information contained in this document. The development of Kaltra products and services is continuous and the information in this document may not be up to date. It is important to check the current position with Kaltra at the address stated. This document is not part of a contract or licence unless expressly agreed. No part of this document may be reproduced or transmitted in any form or by any means, electronic or mechanical, including photocopying, recording, or information storage and retrieval systems, for any purpose other than the purchaser's personal use, without the express written permission of Kaltra.

©2019 Kaltra Innovativtechnik GmbH. All rights reserved. Printed in Germany.

SAFETY

The information contained in this manual is critical to the correct operation and maintenance of the unit and should be read by all persons responsible for the installation, commissioning and maintenance of this Kaltra unit.

The equipment has been designed and manufactured to meet international safety standards but, like any mechanical/electrical equipment, care must be taken if you are to obtain the best results.



CAUTION

When working with any air conditioning units ensure that the electrical isolator is switched off prior to servicing or repair work and that there is no power to any part of the equipment. Also ensure that there are no other power feeds to the unit such as fire alarm circuits, BMS circuits etc.

Electrical installation commissioning and maintenance work on this equipment should be undertaken by competent and trained personnel in accordance with local relevant standards and codes of practice. A full hazard data sheet in accordance with COSHH regulations is available should this be required.

Personal Protective Equipment and Handling

Kaltra recommends that personal protective equipment is used whilst installing, maintaining and commissioning equipment. Some operations when servicing or maintaining the unit may require additional assistance with regard to manual handling. This requirement is down to the discretion of the engineer. Remember do not perform a lift that exceeds your ability.

Ecodesign Directive

The product range within this document is designed in accordance to the European Ecodesign Directive 2009/125/EC.

CE Directive

Kaltra certify that the equipment detailed in this manual conforms with the following EC Directives:

Electromagnetic Compatibility Directive (EMC)	2014/30/EU
Machinery Directive (MD)	89/392/EEC version 2006/42/EC
Pressure Equipment Directive (PED)	2014/68/EU
Ecodesign	2009/125/EC

To comply with these directives appropriate national & harmonised standards have been applied. These are listed on the Declaration of Conformity, supplied with each product.



IMPORTANT

Apply unit specification provided by Kaltra to check project specific unit characteristics, such as unit dimensions, the number and layout of fans, predicted performance, dry and operating weights, start and operating currents, design fluid flow and limits, fluid composition, unit water side pressure drop, airflow and others.

Unit specifications at various project conditions and unit general arrangement drawings are available from Kaltra upon request.



IMPORTANT

Apply unit drawings and electrical schematics supplied by Kaltra to define certain model parameters, optional features installed, component data, external service requirements. Unit drawings, electrical wiring, and control schematics are supplied with the equipment or available upon request within the manufacturing.

CONTENT

Customer Services	2
Commissioning, Maintenance and Warranty	2
Spares	2
Training	2
Service Contacts	2
Safety	3
Personal Protective Equipment and Handling	3
Ecodesign Directive	3
CE Directive	3
Introduction	5
Purpose of Present Manual	5
Unit Description	5
Model Identification	5
Unit Components and Construction	6
Painted Galvanized Steel Enclosure	6
AC Fan Motors	6
EC Fan Motors - Optional	6
Heat Exchanger	6
Electrical Components and Wiring - Optional	6
Main Electric Isolator - Optional	6
Heat Exchanger Coil Guard - Optional	6
Air Filtration - Optional	6
Shut-Off Valves - Optional	6
Discharge Air Plenum - Optional	6
Fan Diffusers - Optional	6
Variable Speed Control - Optional	6
Adiabatic Spray System- Optional	6
Operating Limits	7
Storage, Handling, and Transportation	8
Transportation and Storage Conditions	8
Lifting	8
Unpacking	8
Installation	9
Positioning and Levelling	9
Horizontal Air Discharge Units	9
Vertical Air Discharge Units	9
Minimum Clearances	9
Vertical Air Discharge Units	10
Horizontal Air Discharge Units	10
Electrical Connections	11
Process Fluid Connections	11
Process Fluid Pipework Installation	11
Maintenance	12
Maintenance Schedule	12
Three-Months Interval	12
Six-Months Interval	12
Warranty	13

INTRODUCTION

Purpose of Present Manual

The purpose of this manual is to inform service technicians of Mistral series flatbed dry coolers manufactured by Kaltra. This manual covers Mistral Series unit components and construction, and handling, design guidelines, installation, and maintenance procedures.

IMPORTANT

All personnel being responsible for the operation, installation, and maintenance of present units must carefully read and fully understand these instructions before transportation, loading/unloading, handling, installing, and carry out maintenance procedures.

Unit Description

Mistral Series units are high-performance dry coolers intended for cooling water, glycols, brines, and special fluids. The series designed for outdoor installation for vertical or horizontal airflow. The units equipped with heat exchangers with round copper tubes and plate aluminum fins, axial fans driven by AC or EC motors, and epoxy-painted steel enclosure. As standard, the units supplied with AC-driven fans. Options include EC-driven fans, fan diffusers, wiring, electrical box, and more (please refer to the corresponding section of the present manual).

Model Identification

Mistral			L	W	-	63	-	41	A	4	EC
Heat exchanger size	L	Standard									
	XL	Large									
		Extra-large									
Application	W	Dry cooler									
Fan diameter		Diameter in mm-10									
Number of fans		Fans per row									
		Number of rows									
Heat exchanger type (internal)		A/B/C types									
Number of fan motor poles											
Fan motor type	AC	D/Y/S									
	EC	EC-driven									

The model code can be found on the name plate under the front cover of the unit (unit connection side):



Kaltra Innovativtechnik GmbH
 Max-Reger-Str. 44
 90571 Schwaig
 Germany
 Tel.: +49 (0) 911 715 320 21
 Email: info@kaltra.de

UNIT SERIES
MISTRAL
 MODEL
LW63-41A4EC

Supply voltage	[V/Ph/Hz]	400/3/50
Absorbed current [FLA]	[A]	14.3
Fluid volume	[L]	124
Max pressure	[bar]	16

Serial number M17-01035
 Year of manufacturing 2017

Made in EU



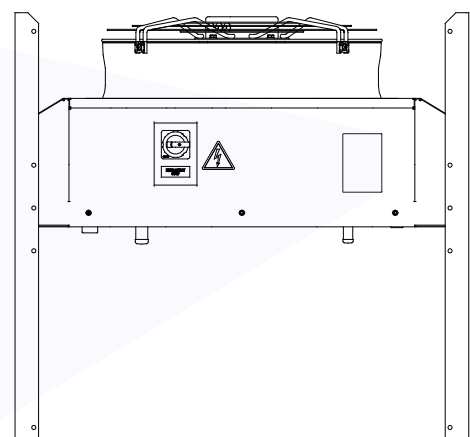

UNIT COMPONENTS AND CONSTRUCTION

Painted Galvanized Steel Enclosure

The unit shall be coated with epoxy baked powder paint to provide a durable finish. The paint color shall be Signal White (RAL 9002) or similar.

AC Fan Motors

The external rotor AC motor shall allow the use of a low power output, single- or three-phase, and speed controllable motor to power the fan. The motor shall have inbuilt thermal overload protection and the assembly shall be supplied complete with a finger guard for protection.

EC Fan Motors - Optional

The fans shall incorporate external EC rotor motor technology to provide highly accurate discreet speed control. The fans offer maximum airflow performance while keeping sound levels to a minimum. Each fan shall incorporate electronically commutated DC motor control using semiconductor modules responding to a signal from the indoor unit or an independent control module for standalone units.

Heat Exchanger

Large surface area heat exchanger positioned to optimise airflow and heat transfer rate, shall be manufactured from round copper tubes aluminum fins. The factory test pressure shall not be less than 16 bar.

Electrical Components and Wiring - Optional

All electrical components shall be rated for all year round outdoor use. All wiring (optional) shall be color coded and numbered for identification. All units shall be wired in accordance with current European standards.

Main Electric Isolator - Optional

A weatherproof mains isolator shall be fitted to ensure complete unit isolation of the electrical panel during adjustment and maintenance.

Heat Exchanger Coil Guard - Optional

Protective mesh guards can be fitted to each of the outer coils to protect against damage and shall be removable.

Air Filtration - Optional

The air filtration media shall be heavy duty commercial grade polycarbonate that can be removed for maintenance purposes.

Shut-Off Valves - Optional

The unit can be fitted with shut-off valves on inlet and outlet fluid connections.

Discharge Air Plenum - Optional

Factory fitted, constructed from galvanized sheet steel and coated with epoxy baked powder paint, this plenum shall direct discharge air vertically which reduces air recirculation and provides a degree of acoustic reduction in the horizontal plane.

Fan Diffusers - Optional

Factory fitted fan diffusers to boost fan efficiency and reduce the operating noise of the unit.

Variable Speed Control - Optional

The fan speed is controlled via alteration of the supply voltage which corresponds to a particular process water outlet temperature. The option is available for the units equipped with AC-motor fans.

Adiabatic Spray System - Optional

Direct adiabatic water spray system to provide adiabatic cooling effect via intermittent water spray on incoming air stream of unit's heat exchangers.

Unit model	NORMAL NOISE LEVEL	LOW NOISE LEVEL	ULTRA-LOW NOISE LEVEL	HIGH-PERFORMANCE FANS
Painted galvanized steel enclosure	■	■	■	■
AC fan motors	■	■	■	■
EC fan motors	□	□	□	□
Round tube plate fins Cu/Al heat exchanger	■	■	■	■
Electrical components and wiring	□	□	□	□
Main electric isolator	□	□	□	□
Coil guard	□	□	□	□
Air filtration	□	□	□	□
Shut-off valves (loose)	□	□	□	□
Discharge air plenum	□	□	□	□
Fan diffusers	-	-	-	■
Variable speed control w/ Modbus	□	□	□	□
Adiabatic spray system	□	□	□	□

- Standard components/features
- Optional components/features
- Component/feature not available

Operating Limits

Outdoor air conditions	
Minimum air dry bulb temperature (units w/ AC-fans)	°C -40.0 ¹
Minimum air dry bulb temperature (units w/ EC-fans)	°C -25.0 ¹
Maximum air dry bulb temperature	°C 60.0

¹ - It is a customer responsibility to use appropriate glycol concentration or other methods to avoid fluid freezing during low ambient conditions

STORAGE, HANDLING, AND TRANSPORTATION



CAUTION

During transportation and handling, avoid exerting undue pressures, accidental hits, and avoid any shocks that could damage the product.

Transportation and Storage Conditions

During transportation and storage of the unit:

- Do not remove the packing
- Store the unit in dry enclosed space protected from water of any kind or direct sunlight
- Storage temperature should be between -40°C and +60°C without water condensation
- Units carefully protected and preserved for transportation and storage for the period of 3 months. If a unit shall be stored longer before the installation it should be carefully unpacked, inspected by specialists and repacked after 3 months period from the date of the delivery



WARNING

In case of any visible damage revealed immediately contact Kaltra for further investigation.

Lifting

Units shipped fixed on pallets. Better to use forklift for unit lifting and moving.

Notes:

- It is necessary to follow local regulations and practice for lifting of the units of certain type, weight and dimensions
- If the unit is damaged it should be immediately checked and described in respective report
- The unit should be lifted slowly and evenly, with maximum protection to people around
- The unit should be lifted by eyeholes and better with all packing on. If straps are using for lifting they should be put on properly to be sure that straps do not damage the unit
- The unit should be well supported and balanced during lifting and handling procedure. Take care to observe actual loading point information



WARNING

The unit should be moved by lifting specialists.



IMPORTANT

Check the unit is as ordered, discrepancies or transit damage should be reported to Kaltra immediately. Care should be taken to ensure the unit does not sustain damage before it is lifted into final position. It is strictly prohibited to use the connections, which are delicate parts of the coil, as anchoring points when lifting or handling the unit. This would cause serious damage to the coil and serious risks for the safety of persons and goods.



WARNING

Kaltra accepts no responsibility for any mishandlings during unit lifting or moving.

Unpacking

Shift the product to a location closer to the final installation site prior to unpacking the unit.

- The unit should be carefully unpacked, checked for any damages and completeness. In case of any damage or shortage it should be reported to Kaltra immediately
- Package materials should be recycled in accordance with local regulations

INSTALLATION

The installation of the units and complete system should be carried out by trained and experienced specialists in accordance with common refrigeration practice, recommendations of a present manual, local rules and requirements and directives in force.



IMPORTANT

Kaltra takes no responsibility for improper installation, which may cause system malfunction or damage to the equipment.

System designer and installing engineer should be responsible for checking and observing all the requirements in accordance with system application and installation.

Positioning and Levelling

When positioning the unit, follow the below rules:

- Allow at least the minimum recommended clearances for maintenance and service. See the appropriate section of present manual
- The base for unit positioning should be levelled to ensure unit case geometry
- The base for unit positioning should be stable and strong to carry an equipment of its size and weight
- Do not use crowbars or similar devices for the positioning as they can damage the unit
- Check if required free space available around the unit for the maintenance
- Check if required free space available to avoid airflow restrictions
- Check if all required service connections are accessible to the unit

Horizontal Air Discharge Units

As standard, unit legs are attached and delivered in the horizontal air discharge mode as are the isolator and fan speed controller.

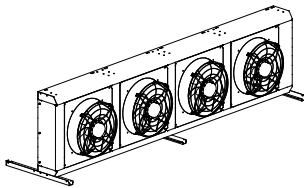

Vertical Air Discharge Units

As standard, unit legs shall be attached and delivered in the horizontal air discharge mode and shall be repositioned on site to offer vertical air discharge mode.

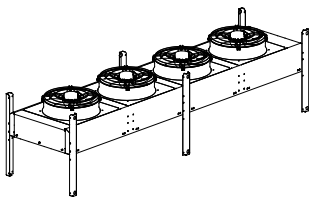

Minimum Clearances



IMPORTANT

During installation, minimum clearances shall be maintained for unit servicing, refrigerant, hydronic, and electrical connections and air distribution.

Vertical Air Discharge Units

Air-distribution and unit servicing for units with vertical air discharge:

- Adequate clearance must be maintained in back of the unit for air suction, in front of the unit for free air discharge
- Ensure that there is adequate clearance below the unit to avoid suction of mud, dirt, or snow with the air stream
- Ensure that there is sufficient space available for unit connections on the appropriate unit side

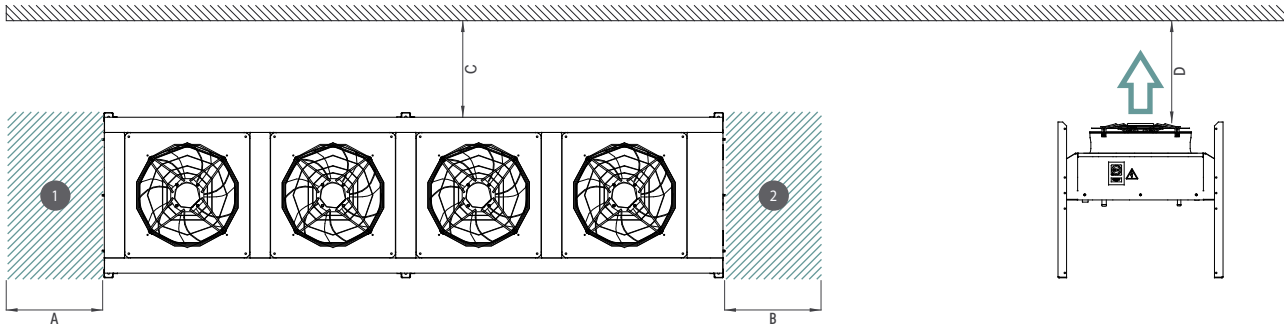

Mistral Series Enclosure size		Minimum clearance			
		A	B	C	D
< 2000mm	mm	400	400	500	2000
2000 - 4000mm	mm	400	600	500	2000
4000 - 6000mm	mm	400	600	750	2000
6000 - 8000mm	mm	400	750	750	2000
8000 - 10000mm	mm	400	800	1000	2000
>10000mm	mm	400	1000	1000	2000

- 1 Service area - electrical box side
- 2 Service area - refrigerant connection side

Horizontal Air Discharge Units

Air-distribution and unit servicing for units with horizontal air discharge:

- Adequate clearance must be maintained in back of the unit for air suction, in front of the unit for free air discharge
- Ensure that there is adequate clearance below the unit to avoid suction of mud, dirt, or snow with the air stream
- Ensure that there is sufficient space available for unit connections on the appropriate unit side

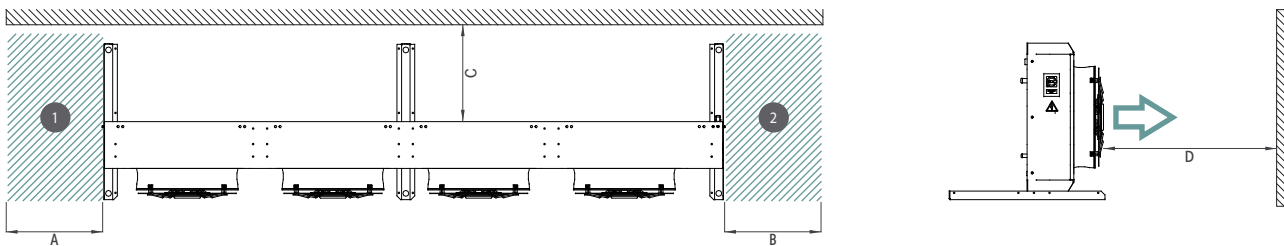

Mistral Series Enclosure size		Minimum clearance			
		A	B	C	D
< 2000mm	mm	400	400	1000	2000
2000 - 4000mm	mm	400	600	1250	2000
4000 - 6000mm	mm	400	600	1250	2000
6000 - 8000mm	mm	400	750	2000	2000
8000 - 10000mm	mm	400	800	2000	2000
>10000mm	mm	400	1000	2000	2000

- 1 Service area - electrical box side
- 2 Service area - refrigerant connection side

Electrical Connections

Single- or three- phase electrical service is required for all models. Electrical service must conform to national and local electrical codes. Refer to equipment nameplate regarding wire size and circuit protection requirements. Refer to electrical schematic when making connections. Refer the appropriate submittal drawing for electrical service entrances into unit.



WARNING

Improper wire sizing/rating and loose electrical connections can cause overheated wire and electrical connection terminals resulting in smoke, fire, equipment and building damage, injury or death. Use correctly sized copper wire only and verify that all electrical connections are tight before turning the power on.



WARNING

Arc flash and electric shock hazard. Open all local and remote electrical power supply disconnect switches, verify with a voltmeter that power is off and wear appropriate personal protective equipment before working within the electric control enclosure. Failure to comply can cause severe injury or death. Customer must provide earth ground to the unit as per applicable codes and regulations. Before proceeding with installation, read all instructions, verify that all the parts are included and check the nameplate to be sure the voltage matches available utility power. The controller does not isolate power from the unit. The factory-supplied, optional disconnect switch is inside the unit. The only way to ensure that there is no voltage inside the unit is to install and open a remote disconnect switch. Refer to the unit electrical schematic. Follow all local codes and regulations.

Improper electrical connection of three-phase input power can cause unit damage. Service technicians should use a gauge set on the system during the initial start up to verify that the three-phase power is connected properly.

Connecting power to the unit:

- Use suitable equipment to check the grounding system efficiency
- Ensure that the facility voltage and frequency correspond to those of the unit name plate
- Ensure the main disconnect switch is in the off position
- Refer to wiring diagram supplied with the unit and connect the building power supply line to the voltage terminals appropriately

Process Fluid Connections

The unit shall be connected to fluid pipework using appropriate connection type, size, and pressure ratings. Please refer to submittal drawings supplied with the unit.

Process Fluid Pipework Installation

Process fluid pipework shall be installed as per accepted practices, international and local regulations, and taking into account all the requirements of the present manual.



IMPORTANT

It is the responsibility of the installing contractor/site engineer to check the pipe size is correct for each system installation and application. Design should be in accordance with accepted practices to ensure correct unit operation.



IMPORTANT

Kaltra takes no responsibility for improper pipework installation, which may cause system malfunction or damage to the equipment.



CAUTION

All work must be carried out by technically trained and competent personnel.

MAINTENANCE



CAUTION

All work must be carried out by technically trained competent personnel. The equipment contains live electrical and moving parts, isolate prior to maintenance or repair work.



WARNING

It is owner responsibility to provide scheduled unit and system maintenance in accordance with the schedule and requirements mentioned below. Incorrect maintenance within warranty period invalidates warranty obligations of the manufacturer. It is important to follow maintenance schedule as a minimum not only for warranty period but for the whole life time of the equipment.

- All system parameters checked should be carefully written down on maintenance sheet, compared with those from unit commissioning sheet and previous maintenance records
- Appropriate service tools, test and safety equipment should be employed for maintenance works



WARNING

The unit contains live electrical terminals and moving elements which should be isolated remotely before any maintenance works.

Maintenance Schedule

The maintenance schedule indicates the time between maintenance operations. It is necessary to carry out all maintenance tasks described below in case the unit has been stopped for a period longer than three months.

Three-Months Interval

Type	Action	Description
General inspection	Check for visible mechanical damage of the unit	Visually inspect the unit for general wear and tear; treat any paint damage or rust if necessary
	Check for excess vibration from any rotating parts	Check fans and unit enclosure for excess vibration; be careful near rotating equipment components
Cleaning	Check unit fans for mud and dirt	Clean fan motors, impellers, and other components, if necessary. Switch off the unit before cleaning and ensure fans stop rotation
	Check unit heat exchanger for mud, dirt, and debris	Remove debris, clean heat exchanger from mud and dirt. Use appropriate chemicals and rinse heat exchanger when cleaning is completed. Be careful near rotating unit fans

Six-Months Interval

Perform all maintenance tasks specified for three-months interval, as well as the following works:

Type	Action	Description
General inspection	Check electrical connections	Check all electrical connections for tightness
	Check fan amps	Check fan amps current values at each phase
	Check control components	If installed, check control components for proper operation and readings (controller, sensors, EC fans boards, alarm signaling)

WARRANTY

All Mistral Series units or parts (non-consumable) supplied for installation within the EU and commissioned by Kaltra engineers carry a full parts & labor warranty for a period of 36 months from the date of commissioning or 39 months from the date of despatch, whichever is the sooner. Units supplied by Kaltra for installation within the EU or for export that are properly commissioned in accordance with Kaltra standards and specifications, not commissioned by Kaltra engineers carry a 36 month warranty on non-consumable parts only from the date of commissioning or 39 months from the date of despatch, whichever is the sooner. Parts or equipment installed or commissioned not to acceptable Kaltra standards or specifications invalidate all warranty. Warranty is only valid in the event that equipment is properly protected and serviced as per the Kaltra manuals provided.

In the event of a problem being reported and once the warranty is confirmed as valid under the given installation and operating conditions, Kaltra will provide the appropriate warranty coverage attributable to the rectification of any affected Kaltra equipment supplied (excluding costs for any specialist access or lifting equipment that must be ordered by the customer).

Once the warranty is confirmed, maintenance must be continued to validate the warranty period. Any spare part supplied by Kaltra under warranty shall be warranted for the unexpired period of the warranty or three months from delivery, whichever period is the longer. To be read in conjunction with the Kaltra Terms of Sale, Warranty and Warranty Procedure, available upon request.



Kaltra Innovativtechnik GmbH

Head office:

Max-Reger-Str. 44
90571 Schwaig
Germany



+49(0)911 715 32021



info@kaltra.de



www.kaltra.com

